

Technical Data Bystar

Bystar 3015

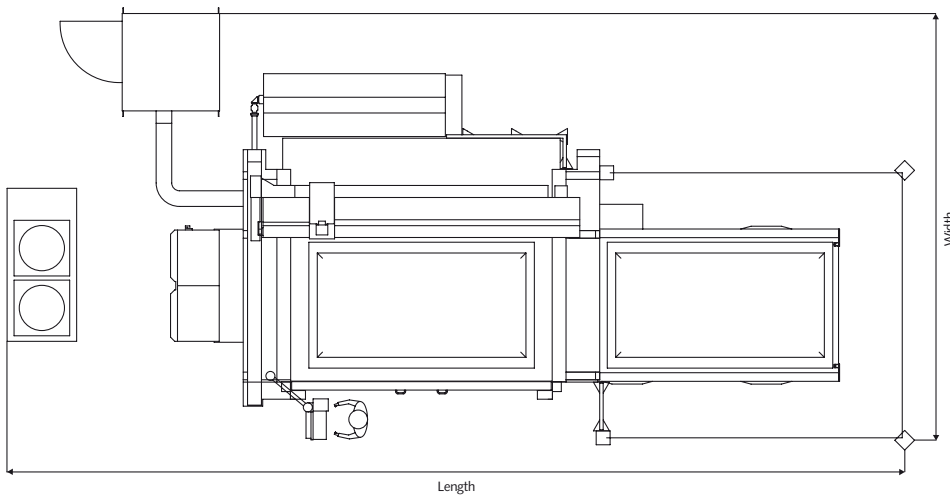
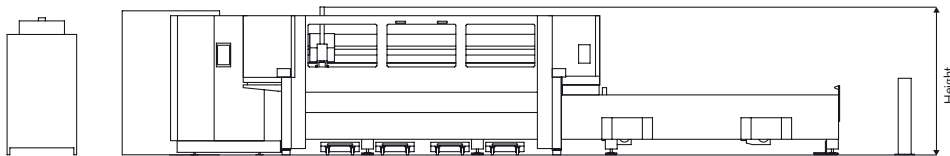

	Bystar 3015 *	Bystar 4020 *	Bystar 4025 *
Length	12 900 mm	16 000 mm	14 750 mm
Width	6 100 mm	6 700 mm	8 050 mm
Height	2 070 mm	2 070 mm	2 950 mm

* with Bylaser 4400/5200 ARC
Measurements with other laser sources on request

Laser cutting system	Bystar 3015	Bystar 4020	Bystar 4025
Nominal sheet size	x = 3000 mm y = 1500 mm	x = 4000 mm y = 2000 mm	x = 4000 mm y = 2500 mm
Cutting range	x = 3048 mm/ 120 in. y = 1524 mm/ 60 in. z = 170 mm/6.70 in.	x = 4064 mm/ 160 in. y = 2032 mm/ 80 in. z = 170 mm/6.70 in.	x = 4064 mm/ 160 in. y = 2540 mm/ 100 in. z = 170 mm/6.70 in.
Maximum positioning speed axis parallel x, y	80 m/min	60 m/min	60 m/min
Maximum positioning speed simultaneous	113 m/min	84 m/min	84 m/min
Maximum axis acceleration	4.5 m/s ²	3 m/s ²	3 m/s ²
Positioning accuracy Pa *	± 0.1 mm	± 0.1 mm	± 0.1 mm
Repeatability Ps *	± 0.05 mm	± 0.05 mm	± 0.05 mm
Edge detection precision	± 0.5 mm	± 0.5 mm	± 0.5 mm
Maximum workpiece weight	890 kg	1580 kg	1970 kg
Machine weight **	13 500 kg	18 300 kg	27 000 kg
Possible laser sources			
Bylaser 4400	•	•	•
Bylaser 5200 ARC	•	•	•
ByLaser 6000	•	•	•
Base	normal, reinforced industrial floor according to assembly plan		
Cutting heads	5" and 7.5"		
Cutting gas consumption	dependent on material		
Operation via panel	with 15" touchscreen, keyboard and manual control unit		
Drives	DVD-RW, USB 2.0		
Network connection	RJ45 connector 10/100 MBit/s		

CO ₂ laser source	Bylaser 4400	Bylaser 5200 ARC	ByLaser 6000
Output	4400 W	5200 W	6000 W
Wavelength	10.6 µm	10.6 µm	10.6 µm
Polarization	circular	circular	circular
Pulse frequency	1–2500 Hz	1–2500 Hz	1–2500 Hz
Maximum sheet thickness ***			
Mild steel	25 mm	25 mm	25 mm
Stainless steel	20 mm	20 mm	25 mm
Aluminum	12 mm	12 mm	15 mm
Maximum electric consumption of the total system ****	56 kW	61 kW	78 kW

* According to VDI/DGQ 3441 measuring length 1 m. The precision of the sheet metal part depends on the material in question and its previous handling as well as the table size and its warming.

** Complete laser cutting system with rotating table without suction, cooling equipment and automation

*** In order to cut the maximum thickness, the following conditions must be met:

- Optimally suspended and set laser cutting systems
- The materials must be of the quality demanded by Bystronic (laser materials)

**** Entire system with suction and cooling equipment

Changes to dimensions, construction and equipment are reserved. ISO 9001 certified

Bystronic: Best choice.

Laser | Bending | Waterjet
bystronic.com